

Users' Manual for HG600 Mobile Humidity Generator



Limited Warranty and Responsibilities

Guarantee that ZOGLAB products have no imperfection in its materials and workmanship within one year from the purchase date, but the replaceable battery or the products damaged by accident, negligence, misuse, or application in unusual circumstances, are all not included. The warranty period has not been extended for distributors specially from ZOGLAB. If any repairs are required within the warranty period, please send defective devices together with the problem notice to the dealer you purchased from.

This warranty is the only compensation for you. Except this, ZOGLAB makes no express or implied warranties(eg. to guarantee the suitability for a particular purpose). In no event shall ZOGLAB be liable for any special, indirect, incidental or consequential damages or losses arising from any cause or conjecture. As certain regions or countries do not allow limitations on implied warranties and incidental or consequential damages, the above scope of liability and provisions may not be relevant to you.

Special Note: Due to product upgrades or other reasons, the pictures in the manual, mechanical size and physical differences, please in kind prevail. The document may not be allowed to be reproduced or transmitted in any form or by any means, including electronic and mechanical, for any purpose, without the written permission of ZOGLAB. The Company reserves the right of final interpretation.

Marks Explanation



This mark contains the warning information, please read carefully to prevent equipment damage.



This mark refers to the function details, please read carefully before using the equipment.

ZOGLAB™, HG™ are

registered trademarks of ZOGLAB Microsystem Co., Ltd. No any company or individual may reproduce or transmit in any form without written permission.

China Patent Number: 201530567115.4 Appearance patent Counterfeiting not allowed

For more information, please visit our website <http://www.zoglab.cn>

All rights reserved Ripping not allowed 2002-2022 ZOGLAB Microsystem Co., Ltd

Content

CHAPTER 1 Safety and Cautions

Safety and Cautions	2
---------------------------	---

CHAPTER 2 About HG600

About HG600	5
Structure and Function Description	6
Overall View	6
Overall Function Description	7
Interface Area View	8
Interface Area Function Description	9
LCD Display and Function Description	10
Main Interface View	10
Main Interface Function Description	11
Humidity Function Interface View	12
Humidity Function Interface Description	13

Graphic Interface View	14
Set Value Digital Soft Keyboard View	15
State/Set Value Line Interface View	16

CHAPTER 3 Operation and Application

Connect the Power Supply	21
Add Water	22
Insert the Test Humidity Probe	23
Replace Desiccant	24
Set Humidity	25
Power On/Off	27
Run	28
Program	29
Run Program	30
Analog Signal Measurement	31
Current Measurement	32
Voltage Measurement	33

CHAPTER 4 System Setting

Main System Setting Interface	31
Network Setting	32
Serial Setting	33
Calibration Setting	34
Control Setting	35
Storage Management	36
Time Setting	37
Brightness Setting	38
Sound Setting	39
Language Setting	40
System Information	41
System Upgrade	42
Help	43

CHAPTER 5 Product Information

Specification	45
Technical Specification	45
General Specification	45

Product Dimensions	46
Packing Details	47
Quality Certifications	49

CHAPTER 6 Services

Warranty	51
----------------	----

Appendix

1. Communication Protocol
2. FAQ

CHAPTER 1

Safety and Cautions

Safety and Cautions

HG600 Mobile Humidity Generator is a precision instrument. Non-professional maintenance personnel of the company, please do not conduct repair and modification. Due to man-made causes of equipment work abnormalities, damage or indirect economic losses, the Company shall not be liable.

Before installing and using this equipment, please read the chapter for instructions on Safety and Cautions

1. General Principle

Please use the equipment according to the rules in the manual, or the provided protection will be damaged and can not be used in safety.

2. Before Connecting the Power Supply

Check to confirm if follow the safety precaution. Before connecting the power supply and choosing the suitable voltage in the fuse module, please confirm all the equipment are connected.

3. Connect the Equipment to the Ground

The standard power cord for the instrument is a three-core power cord that connects the live, ground, and neutral wires respectively. Interruption of the protection (ground protection terminal) connection will result in a potential shock hazard and cause personal injury.

4. Working Environment

Do not use the device in the environment of explosion, inflammable gas, steam, smog. Working temperature -10 °C~40 °C; Storage temperature -20 °C~70 °C; Maximum humidity 10%~95%RH (non-condensing). Do not use the device beyond the working environment.

5. Do not disassembly the cover of device

Only the qualified and trained professionals who know the potential risk can open the cover of device. Before opening the device cover, be sure that the electricity is cut off.

6. Do not Adjust the Device

If not professional maintenance personnel from ZOGLAB, please do not do the maintenance, change components, or do the adjustment for the device. If there is something wrong with the device, please contact the supplier for repairing or changing.

7. Device Damage

When the device is in malfunction or damage, please stop operation immediately and avoid misoperation, wait for maintenance from serviceman.

8. Water Inside the Device

If water inside the device by accident, please cut off the electricity immediately; if the device can not work normally, please return it to the sales agency or the factory for maintenance.

9. WEEE Electrical Environmental Protection WEEE

When the device is end of life, please send the e-waste back to us to support the electrical environmental protection.

CHAPTER 2

About HG600

About HG600

HG600 is a Two-flow Mobile Humidity Generator. Based on semiconductor thermostat and ultrasonic humidification fogging technology, various humidity environment can be generated within the set temperature range. Built-in pump circulation and mixing fan allow quick response to reach the set humidity value. Since its stabilization time is less than 10 minutes, HG600 can complete calibration and verification work in a short time.

Reasonable structural design can quickly respond and generate the required humidity stably with better uniformity.

Structure and Function Description

Overall View

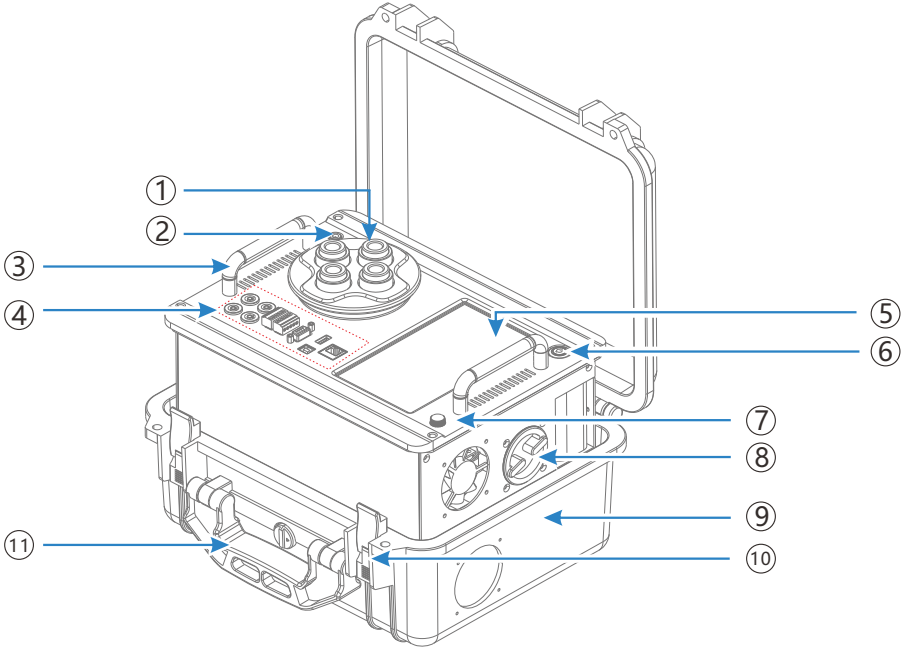

Overall Function Description

S/N	Component Name	Functional Description
①	Chamber cover	Fit 12/15/18mm diameter probe
②	Power interface	Connect power cable
③	Support handle	Move main body of the device
④	Communication/signal interface area	Data communication/acquisition or signal generation
⑤	LCD	Main work screen, touch operation interface
⑥	Power switch	Power on/off
⑦	Water add/drain port	Add water and drainage
⑧	Dryer chamber cover	Open the dryer chamber to change dryer
⑨	Explosion-proof traveling case	Protect instrument
⑩	Sealing buckle	Open or close the traveling case
⑪	Handle	Move whole instrument

Interface Area View

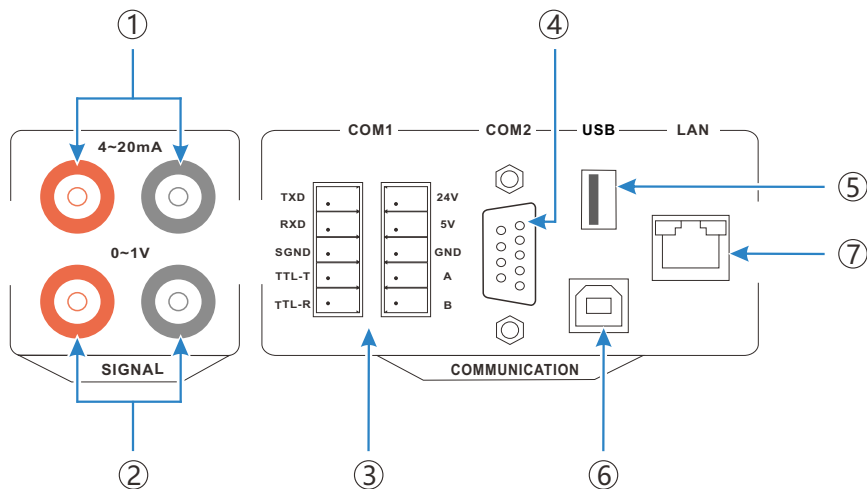

Interface Area Function Description

S/N	Component Name	Functional Description
①	4~20mA measuring interface	Connect 4~20mA output probe
②	0~10V measuring interface	Connect 0~10V output probe
③	COM1	Digital probe communication interface, support RS232/RS485
④	COM2	Upper computer communication interface, support RS232/RS485
⑤	USB-A	USB-A communication interface supports data export
⑥	USB-B	USB-B type communication interface supports upper computer communication
⑦	LAN	Ethernet communication interface

LCD Display and Function Description

Main Interface View

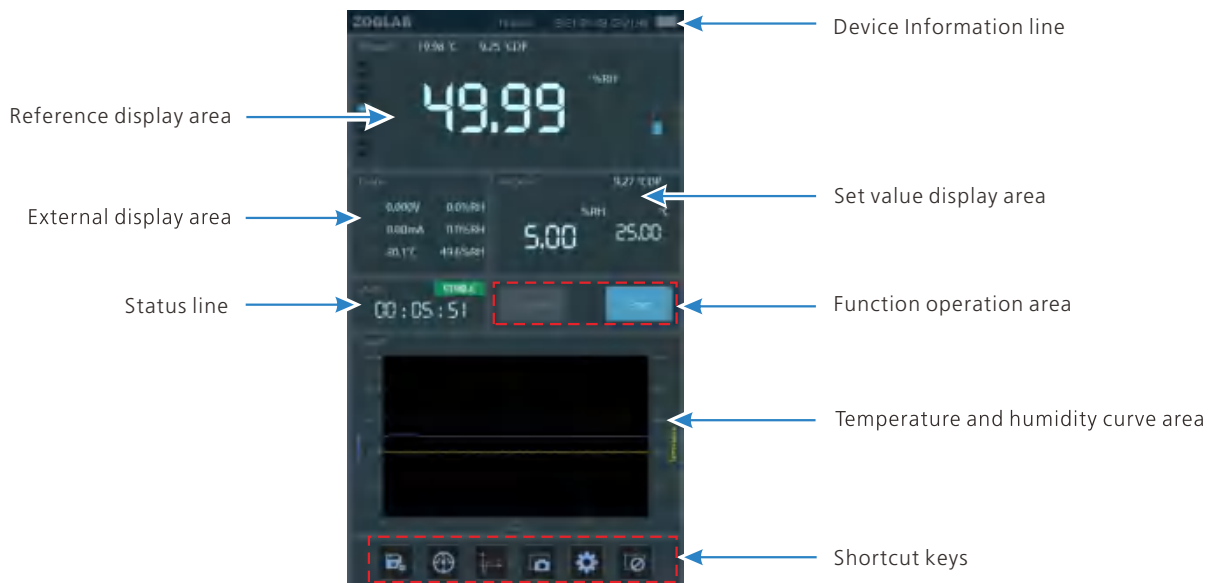

Main Interface Function Description

Component Name	Functional Description
Device Information line	Display Bluetooth, WiFi, battery, instrument name, current year, month, date and Time
Reference display area	Displays the humidity and temperature values of the built-in reference
External display area	Display the measured value of the probe
Set value display area	Display target humidity and temperature control value; click this area to input target value
Status line	Display start, configuration, and other status information
Function operation area	Program and start operations
Temperature and humidity curve area	Display the temperature and humidity curve corresponding to the current/voltage
Shortcut keys	The shortcut keys from left to right are: [storage key] to check the storage status; [lock key] to lock the current humidity value; [screenshot key] to intercept the current screen; [day/night switch key] for day and night mode switch; [set key] to enter the system setting; [screen lock key] to prohibit touch screen operation

Humidity Function Interface View

The upper part of the main interface is the humidity function interface.

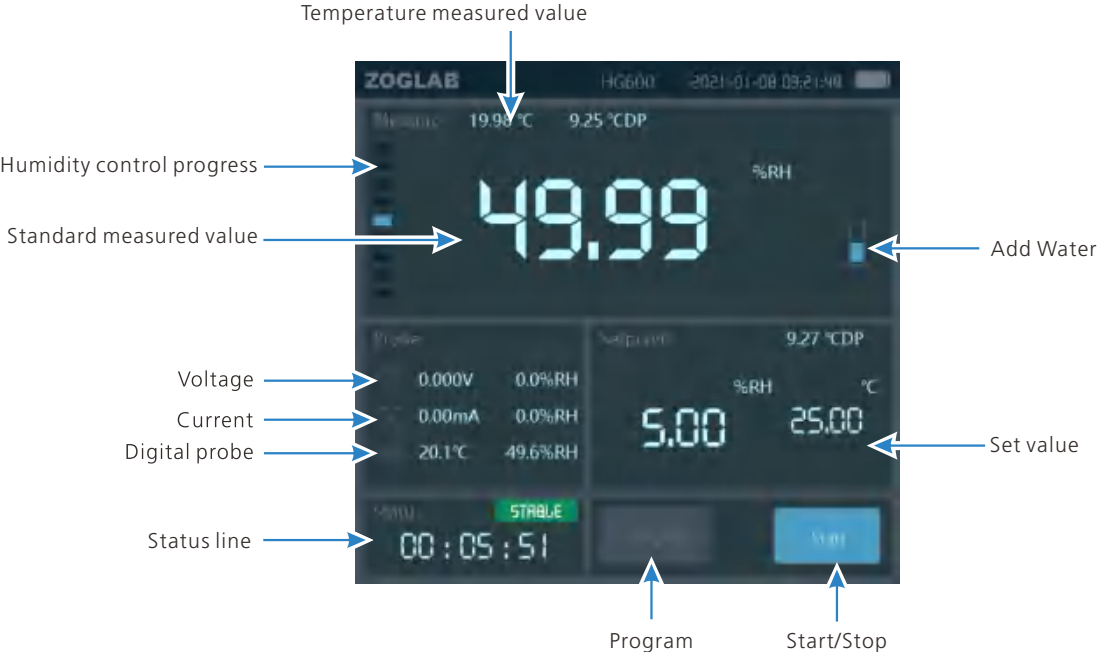

Humidity Function Interface Description

Component Name	Functional Description
Humidity control progress	Display the relative difference between the current measured humidity value and the set value
Reference measured value	Display the measured humidity value
Temperature measured value	Display the measured temperature value
Voltage	Measuring voltage
Current	Measuring current
Digital probe	Measuring probe
Status line	Display start, configuration, and other status information
Set value	Display target humidity control value; click this area to enter target value
Add Water	Click this button to add water; long press this button to pop up the drainage operation reminder to perform drainage operation
Program	Conduct program control, setting step and holding time for easy readings; setting calibration points, stabilization time and error judgments for automatic calibration
Start/Stop	Start and stop operations

Graphic Interface View

The lower part of the main interface is a curve interface, which displays the current change trend of temperature and humidity data.

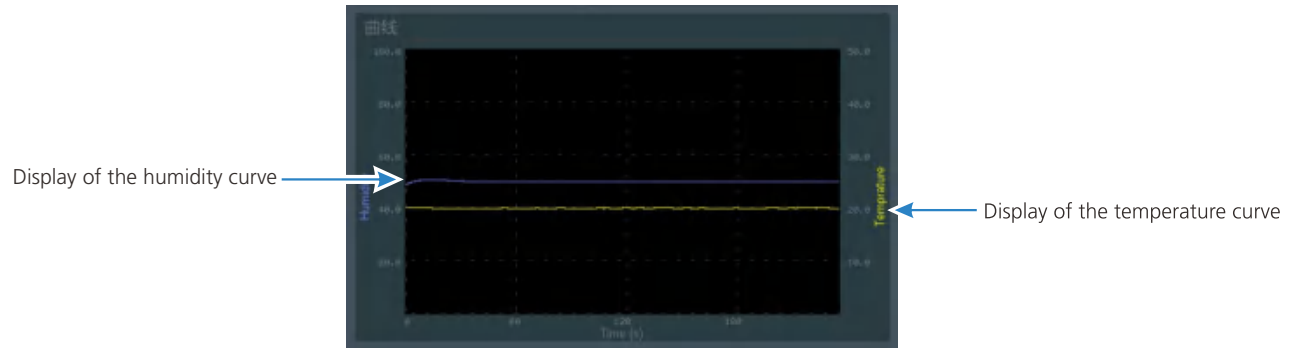

Set Value Digital Soft Keyboard View

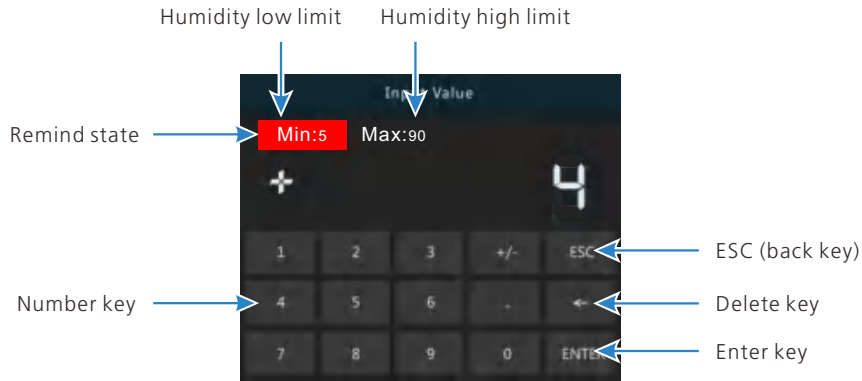

Component Name	Functional Description
Humidity low limit	Control the humidity low limit. The humidity low limit can be changed by "pressure limit" in the control parameter.
Humidity high limit	Control the humidity high limit. The humidity high limit can be changed by "pressure limit" in the control parameter.
Number key	Number input keys
Remind state	When the input target humidity value exceeds the high and low limits, the red bottom will appear for reminder.
ESC (back key)	For canceling, exiting, returning and other operation controls.
Delete key	Delete a character.
Enter key	Confirm the current input value.

Status/Set Value Line Interface View

Display status information for control, measurement, vent, and programming mode. When the programming mode is running, the status line shows the number of control points, and the set value column shows the cycle/single, reset, and clear icons.

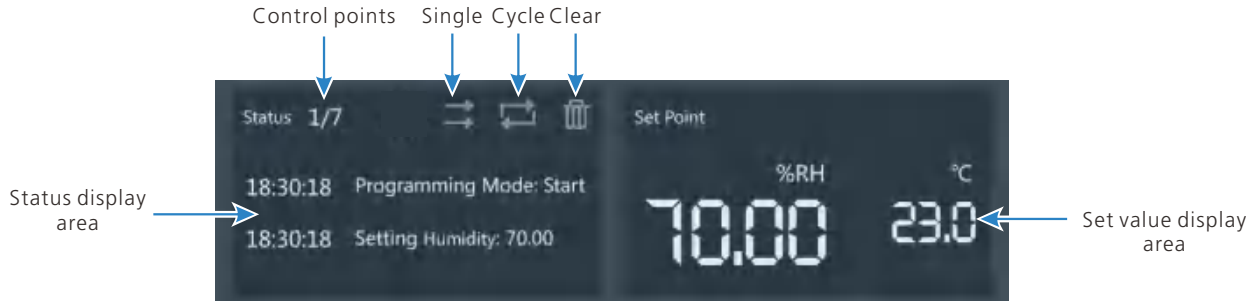

Component Name	Functional Description
Status line	Display the working status
Set value display area	Display the set humidity/temperature value
Control points	Displays the current control point and the total control points for this programming.
Single	Click to switch single mode, single programming icon: ⇌
Cycle	Click to switch the cycle mode, cycle programming icon: ↻
Clear	Clear the current programmed running. This icon is valid when the programming mode is stopped.

CHAPTER 3

Operation and Application

Connect the Power Supply

Take out the 20V adapter from the storage bag , connect one end of the adapter to the power connector on the panel, and connect the other end to a 100 to 240VAC power supply.

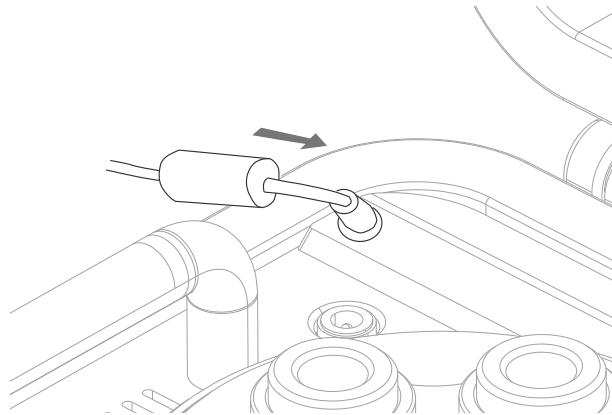

Connect the power cable

HG600 has a built-in battery so that can be skipped the step during outdoor use.

Add water

Open the lid of the “add/drain” port and connect the water pipe. One end of the water pipe is placed in a container with distilled water, and the other end is inserted into the HG600 “add/drain” port. Click the “Add water” button on the main work interface to perform automatic water filling operation from the “Add/Drain” port, and the water tank will automatically stop when it is full.



Add water

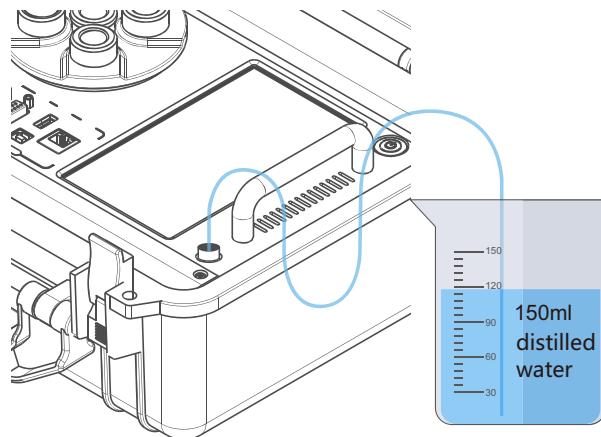

Automatic watering



When moving HG600, please be sure to drain the water in the water tank first.

Insert the Test Humidity Probe

Unplug the chamber cover and insert the test humidity probe for testing.

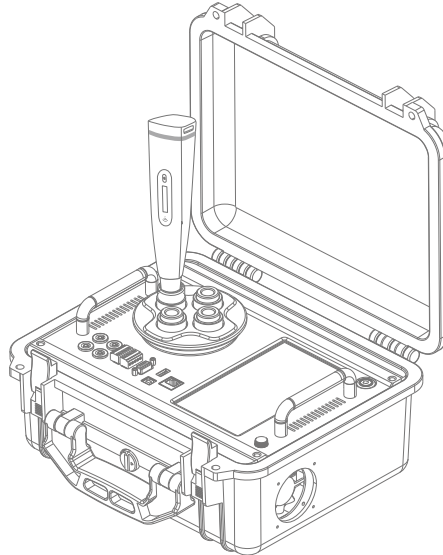

- ☑ If the probe requires external power, the power interface on the panel can be used.

Replace Desiccant

Grasp the support handles on both sides, lift the HG600 main body up from the carrying case, then turn it counterclockwise to open the drying cylinder cover, and take out the drying cylinder to replace the desiccant. After the replacement, insert the drying cylinder and turn it clockwise to close the drying cylinder cover.

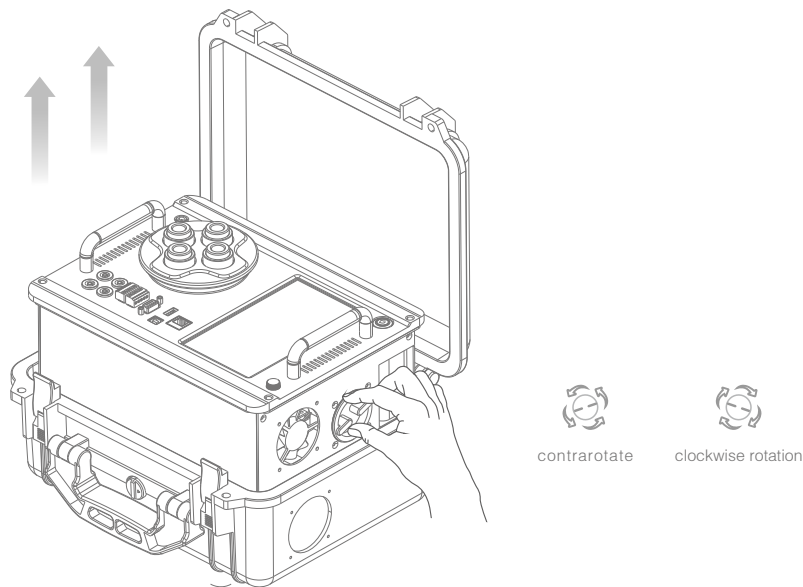

Turn it counterclockwise to open the drying cylinder cover

Set Humidity

Set the target humidity control value. To prevent over-wetting and to reach the best measurement performance, please enter the target value according to the effective range of the instrument. Take that the control range is 10 to 95% RH as an example. If the input target value is outside the valid range, it is invalid.

Target value input mode: Click the “Set value” area to pop up the target value input interface and input the target value through the soft keyboard.

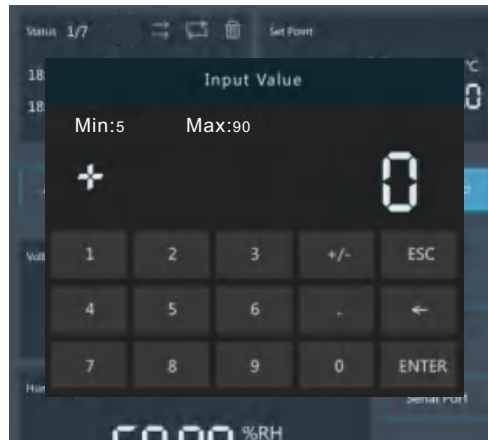

Input the set value interface

-
- ☑ When the input target value exceeds the valid range, beeps and red bottom appear.



Target value < humidity low limit,
red bottom appears



Target value > humidity high limit,
red bottom appears

- ! Please set the target temperature at the same time. When the set temperature and actual temperature deviation exceeds ± 2 °C, the device will automatically stop the humidity control until the temperature is controlled to a suitable value. It is recommended to set a target temperature close to the ambient temperature to save power.

Power On/Off

Press the power button on the right side of the panel and the buzzer will sound once the HG600 is turned on, then enter the initial self-test and main work interface. When the power is on, the power button light is on. Press the power button again to turn it off.

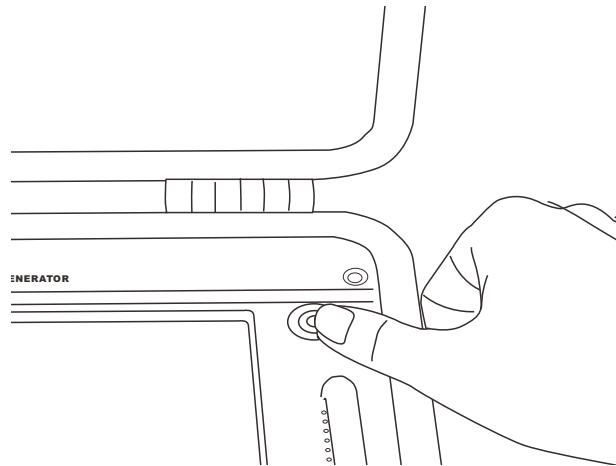

Press the power button

Run

Click the "Start" button on the screen to start up. The measured value display area shows the internal measured humidity of the HG600. When you are done, click the "Stop" button to stop running.



- ! When the value of the numerical display area is close to the target value and the cursor bar turns blue, it indicates that the humidity has stabilized. The operation is completed by comparing the humidity values of the test device with the reference.

Program

Click the “Program” button on the main work interface to enter the programming management interface. Multiple control points can be edited as requested to automatically control the output. The interface can view the program name, the number of control points, the total duration and the program modification time.

In the management interface, click any points of the interface to set the control points, click the “Clear” button, you will delete all the data, click “Cancel” button to exit the program, click the “Run” button to run the program.



ZOGLAB Program Edit

Index	Temp(°C)	Humidity	Time(minute)
01#	25.00	50%	5
02#	25.00	50%	5
03#	25.00	50%	5
04#	25.00	50%	5
05#	25.00	50%	5
06#	25.00	50%	5
07#	25.00	50%	5
08#	25.00	50%	5
09#	25.00	50%	5
10#	25.00	50%	5

Clear

Cancel

Run



ZOGLAB Program Edit

Index	Temp(°C)	Humidity	Time(minute)
01#	25.00	50%	5
02#	25.00	50%	5
03#	25.00	50%	5
04#	25.00	50%	5
05#	25.00	50%	5

ZOGLAB

Range: 0 ~ 35

30

1 2 3 +/- ESC

4 5 6 . C

7 8 9 0 ENTER

Cancel

Run

Programming management interface

Run Program

- (1) Select the program to run in the programming management interface, click the "Run" button to start the programming mode, and jump to the main work interface;
- (2) When the status line indicates that the humidity control is stable, complete a device calibration at one point within the delay time;
- (3) Move to next point calibration, and when the humidity control is stable, then finish the calibration.



Programming mode start interface

Analog Signal Measurement

Current Measurement

Click the "Current" button in the measurement mode, the current measurement range is 4~20mA, and the port is correctly connected according to the connection indication.

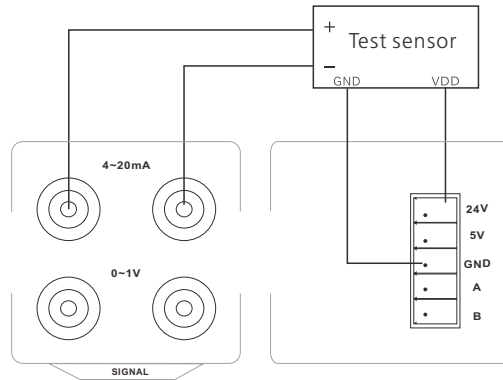

Current measurement connection view

Voltage Measurement

Click the "Voltage" button in the measurement mode, the voltage measurement range is 0V ~ 1VDC, and the port is correctly connected according to the connection indication.

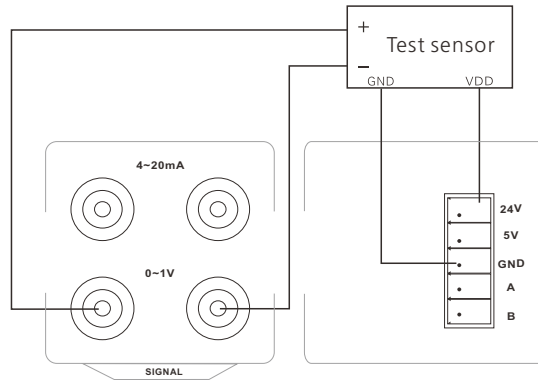

Voltage measurement connection view

CHAPTER 4

System Settings

Main System Setting Interface

Click the setting button  at the bottom of the main work interface to enter the system setting interface. System setting include network(LAN), serial port, calibration, control, storage, time, brightness, sound, language, information, upgrade, and help. Click the "Quit" button to return to the main work interface.



Main setting system interface

Network Setting

Click the system setting interface button  to enter the network setting interface. Enter the IP address, subnet mask, and default gateway from the digital soft keyboard. Click the "OK" button to save the network setting and return to the system setting interface. If no change is required, click the "Quit" button to return to the system setting interface.

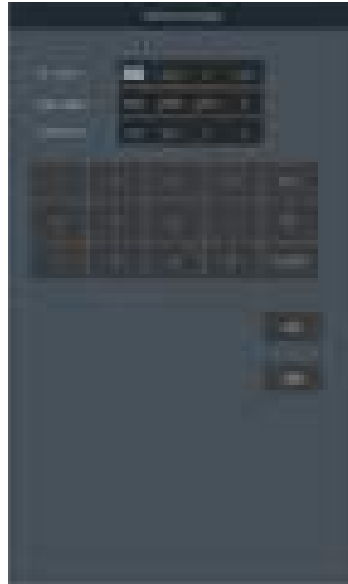

Network setting interface

Serial setting

Click the system setting interface button  to enter the serial port setting interface. Set the baud rate, parity, data bits, and stop bits by clicking the round icon before the parameters. If no change is required, click the "Quit" button to return to the system setting interface.

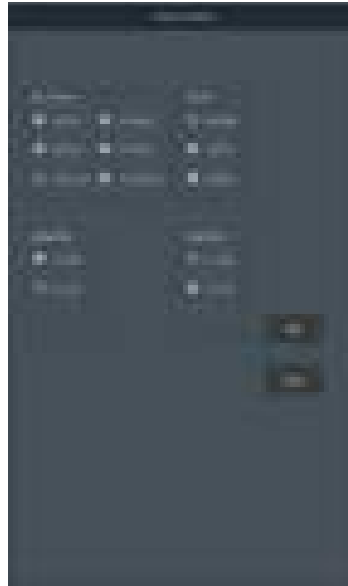

Serial port setting interface

Calibration Setting

Click the system setting interface button  to enter the calibration management interface. The HG600 can be calibrated for its humidity, voltage and current. Click "Quit" button to return to the system setting interface.



Calibration management interface

Control Setting

Click the system setting button  to enter the control parameter setting screen (password required to enter). After editing the control parameters, click the "Write" or "Resume" button to save and return to the control parameter setting interface. If no change is required, click the "Quit" button to return to the system setting interface. (For factory debugging use only and users are prohibited from entering)



Control parameters setting interface

Storage Management

Click the system setting interface button  to enter the storage management interface. You can check the system, USB flash disk storage status, and click the "Quit" button to return to the system setting interface.



Storage management interface

Time Setting

Click the system setting interface button  to enter the time setting interface. Use the digital soft keyboard to modify the year, month, date, and time on the screen. You can also modify the time by clicking the up and down keys. Click "OK" to save the changes. If no change is required, click the "Quit" button to return to the system setting interface.

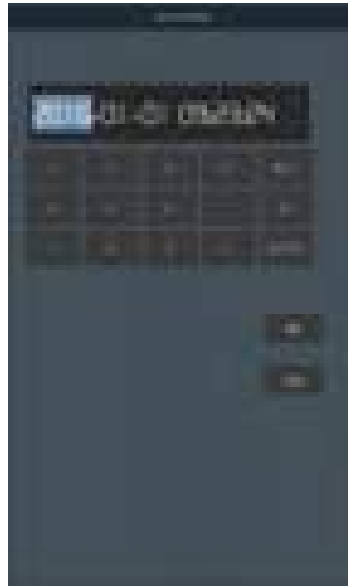

Time setting interface

Brightness Setting

Click the system setting interface button  to enter the light setting interface. Change the backlight brightness of the screen by tapping the light and dark icons on both sides of the screen. The more icons that are lit, the brighter the screen backlight is. Click "Quit" button to return to the system setting interface.



Screen brightness interface

Sound setting

Click the system setting interface button  to enter the beep setting interface. By clicking the square icon before the options, set the press sound and alarm sound. Turn on the "✓" symbol, and the option sound is turn on. Click "Quit" button to return to the system setting interface.

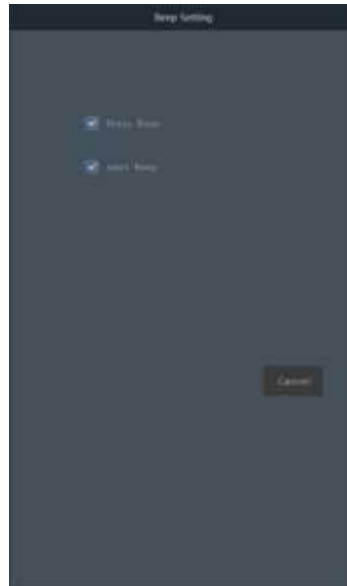

Sound setting interface

Language Setting

Click the system setting interface button  to enter the language setting interface. Select the language by clicking on the round icon before the option. If no change is required, click the "Quit" button to return to the system setting interface.

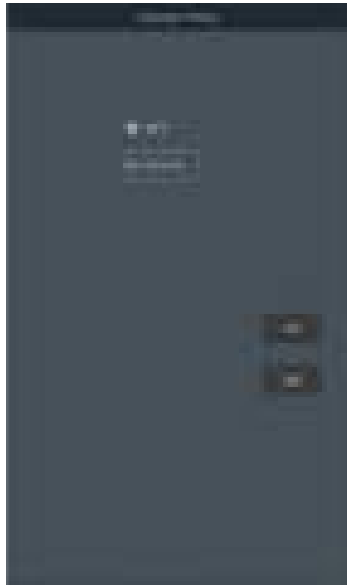

Language setting interface

System Information

Click the system setting interface button  to check the HG600 system information. Click "Quit" button to return to the system setting interface.



System information interface

System Upgrade

Click the system setting interface button  to enter the system upgrade interface and update the system file and control system. The system update requires the supplier to provide the corresponding update file. If the file does not exist, it cannot be updated. Click "Quit" button to return to the system setting interface.

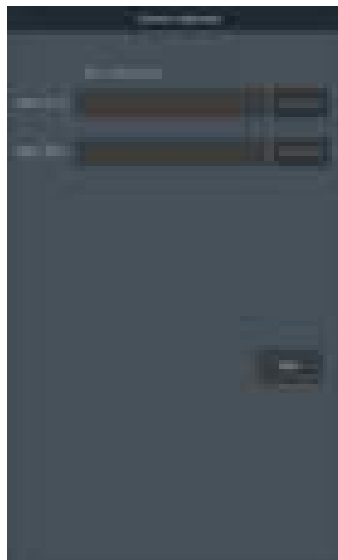

System upgrade interface

-  System upgrade procedure:
1. Connect the update file to the HG600 via the USB-A communication interface and enter the system upgrade interface.
 2. Click the "Update" button next to the required upgrade option to check the progress bar. After the update is completed, restart the instrument and the update takes effect.

Help

Click the system setting interface button  , any questions, please feel free to contact our service hotline: +86-400-8878-571



Check the help interface

CHAPTER 5

Product Information

Specification

Technical Specification

Humidity control range	5%RH~90%RH
Temperature control range	10°C~40°C
Humidity stability	±0.2%RH
Temperature stability	±0.1°C(23°C±2°C),±0.2°C(Full scale)
Humidity accuracy of standard probe (23°C)	±1.0%RH(10~90%RH); ±2.0%RH(≤10, ≥90%RH)
Temperature accuracy	±0.2°C
Temperature and humidity stability of the verification chamber	±0.2%RH; ±0.1°C
Temperature and humidity uniformity in the verification chamber	±0.3%RH; ±0.2°C
Humidity adjustment response time	30%RH change in less than 5 minutes
Average heating rate	3.0°C/分
Average cooling rate	1.0°C/min (ambient temperature is lower than 23°C)

General Specification

Calibration chamber inner diameter size	Φ70.5×37mm
Calibration window size	Φ14~19mm, special size optional
Battery type	Lithium polymer, 16.8V 9600mAh
Battery life	Around 4-8hours.
Operating environment	-10°C~40°C, 10%~95%RH(No condensation)
Storage environment	-20°C~70°C, 10%~95%RH(No condensation)
Desiccant	Molecular sieve desiccant
Power supply	100~240VAC 1.5A, 50/60Hz
Digital signal interface	RS232/485, USB, LAN, Wi-Fi*
Analog signal interface	4~20mA, 0~1V
Dimensions	335mm ×290mm ×155mm
Weight	8kg
Certificates	CE, FCC, VCCI, C-TICK

Product Dimensions(mm)

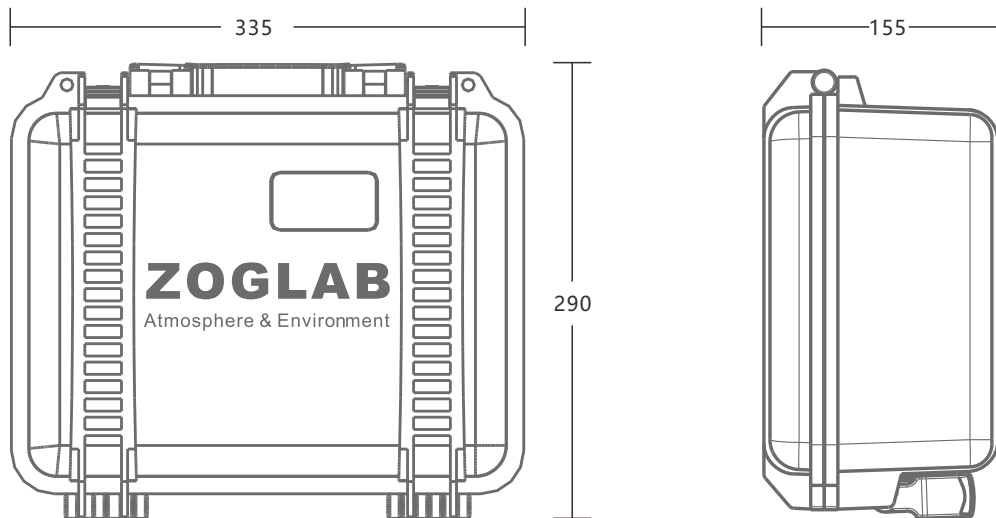

Packing Details

Please confirm the following items in the package:

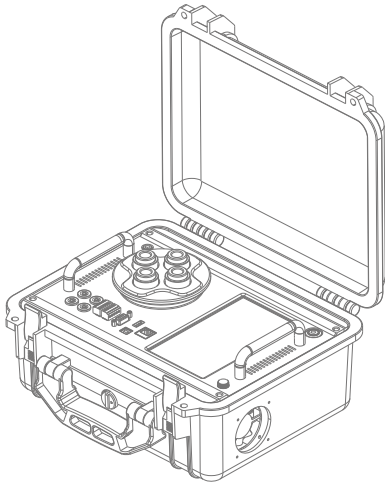

HG600 Mobile Humidity Generator



USB communication cable

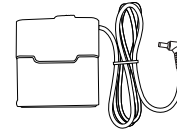

Power adapter



LAN communication cable



PU pipe

Chamber Cover*

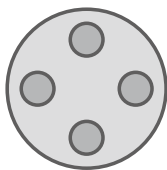

M01
Φ 15~18 × 4

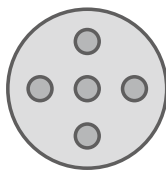

M02
Φ 12 × 5

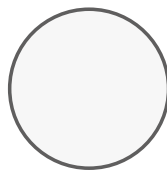

M03
Transparent acrylic cover

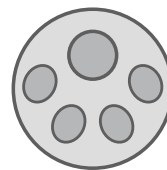

M04
Φ 15~18 × 4
DSP2000 dew point probe



Calibration Certificate



Users' manual



Maintenance manual



Warranty card



Qualification



WEEECARD

*Optional accessories

Quality Certifications

HG600 Mobile Humidity Generator has a number of patents, and has obtained the European CE certification, the United States Federal FCC certification, Australia C-TICK certification, Japan VCCI certification.



HG600 Mobile Humidity Generator is tested and certificated by the world-renowned certification authority **SGS**

CHAPTER 6

Services

Warranty

Thank you for purchasing our products, in order to protect your legitimate rights and interests, please read the following warranty carefully after purchase. From the purchase date, the host is for five years' warranty and one year for accessories.

The following conditions are not covered within the warranty:

1. Failure to follow the instructions specified in the user's manual or precautions may result in malfunction or damage to the product.
2. Warranty bar code does not match with the code on fuselage, or bar code modification and torn off.
3. Beyond the product warranty period.
4. Human or irresistible factors cause product malfunction and damage.
5. Unauthorized disassembly of the instrument.

* Login ZOGLAB official website registered as a member, you can enjoy the relevant services. For more information, please call the service hotline +86-400-8878-571

Appendix 1

Communication Protocol

Function	Command	Return	Description
Read equipment information	AT*TakeInfo	AT*TakeInfo DeviceID: HG600S201802020001A Manufacturer: ZOGLAB Microsystem Co.,Ltd Ver: 1.10, 1.11 OK!	S/N Manufacturer Hardware, software version
Reboot the system	AT^Reboot	AT^Reboot OK!	
Reading humidity	AT*ReadSensor:0	AT*ReadSensor:0 T= 24.5°C RH= 48.8%RH OK!	

Function	Command	Return	Description
Set humidity	AT+SetPoint:0,(10-95)	AT+SetPoint OK!	(10-95) 10-95%RH
Read the set humidity	AT*ReadSetPoint:0	AT*ReadSetPoint SetPoint:95.00 %RH OK!	
Read stable status	AT*ReadStable:0	AT*ReadStable Stable:1 OK!	1 is stable, 0 is not stable

Function	Command	Return	Description
Set backlight	AT+SetLight=(1-8)	AT+SetLight OK!	(1-8) 1-8 brightness
Read backlight	AT*ReadLight	AT+ReadLight LcdBackLight:6 OK!	
Set system time	AT+SetTime=18-01-12 15:44:12	AT+SetTime OK!	
Read system time	AT*ReadTime	AT*ReadTime Time:18-01-12 15:44:12 OK!	System time

Function	Command	Return	Description
Set IP address	AT+SetIPAddr=192.168.0.100	AT+SetIPAddr OK!	
Read IP address	AT*ReadIPAddr	AT*ReadIPAddr IPAddr:192.168.0.100 OK!	IP address
Set gateway	AT+SetGateWay=192.168.0.1	AT+SetGateWay OK!	
Read gateway	AT*ReadGateWay	AT*ReadGateWay GateWay:192.168.0.1 OK!	Gateway

Function	Command	Return	Description
Set subnet mask	AT+SetNetMask=255.255.255.0	AT+SetNetMask OK!	
Read subnet mask	AT*ReadNetMask	AT*ReadNetMask NetMask:255.255.255.0 OK!	Subnet mask
Set DNS	AT+SetDNS=202.101.172.35	AT+SetDNS OK!	
Read DNS	AT*ReadDNS	AT*ReadDNS DNS:202.101.172.35 OK!	DNS

Appendix 2

FAQ

FAQ	Troubleshooting
Unable to start	charge a battery
The screen is dim	Enter the system settings to adjust the backlight brightness of the screen.
Unable to reach Low humidity for a long time	If the desiccant fails, please replace the desiccant in time.
Unable to reach high humidity for a long time	If the water tank is short of water, please add water; or the set target temperature is too low.